



Specification for Approval

Customer: _____

Model Name: _____

Supplier Approval			Customer approval
R&D Designed	R&D Approved	QC Approved	
<i>Peter</i>	<i>Peng Jun</i>		



RECORD OF REVISION

REV NO.	REV DATE	CONTENTS	Note
A	2024-09-25	NEW ISSUE	

TABLE OF CONTENTS

List	Description	Page No.
	COVER	1
	REVISION RECORD	2
	TABLE OF CONTENTS	3
1	GENERAL DESCRIPTION	4
2	MECHANICAL SPECIFICATION	5
3	PIN DESCRIPTION	6
4	ELECTRICAL CHARACTERISTICS	7
5	OPTICAL CHARACTERISTICS	7
6	PIXEL FORMAT	11
7	RELIABILITY TEST ITEMS	12
8	GENERAL PRECAUTION	13
9	PACKAGE DRAWING	14

1.1 DESCRIPTION

AM-8001280-070E is a color active matrix thin film transistor (TFT) IPS liquid crystal display (LCD) that uses amorphous silicon TFT as a switching device. It is composed of a TFT LCD panel, Driver IC, FPC and Backlight.

1.2 FEATURES:

No.	Item	Specification	Unit
1	Panel Size	7"	inch
2	Number of Pixels	800×1280	pixels
3	Active Area	94.2 x 150.72	mm
4	Pixel Pitch	0.11775 x 0.11775	mm
5	Outline Dimension	99.65 (H)×160.85(W)×2.5(D)	mm
6	Number of Colors	16.7M	-
7	Display Mode	Normally black	-
8	Viewing Direction	IPS	-
9	Display Format	RGB vertical stripe	-
10	Luminance (cd/m ²)	300(TYP.)	CD/M2
11	Contrast Ratio	700(TYP.)	
12	Surface Treatment	Anti-Glare	-
13	Interface	MIPI	-
14	Backlight	White LED	-
15	Operation Temperature	-10~50	°C
16	Storage Temperature	-20~60	°C
17	Weight	TBD	g
18	IC	9365DA-H3	

2. MECHANICAL SPECIFICATION

Notes:

- 1 LED CIRCUIT DIAGRAM
- LED: 5*4=20 PCS
- 2 ROHS must be complied.
- 3 Δ Modification rev number
- 4 Draft angle 15°
- 5 All radii without dimension R0.3 , Unspecified Tolerances |±|±0.2

Electrical-Optical Characteristics (T_a=25°C):

ITEM	SYMBOL	MIN. TYP.	MAX.	UNIT
Forward Voltage	V _F	14	16	V
Forward Current	I _F	—	80	mA
Luminous Intensity	L _v	250	300	cd/m ²
Luminous Uniformity	Avg	75	—	%
Color Chromaticity	X	0.26	0.29	—
	Y	0.27	0.30	—
Operating Temperature	T _{opr}	-10° C	+50° C	° C
Storage Temperature	T _{stg}	-20° C	+60° C	° C

LED CIRCUIT DIAGRAM:

CONDITIONS:

Pin No. Symbol Description

1	LED1	Power supply for LED(Anode)
2	LED2	Power supply for LED(Anode)
3	LED3	Power supply for LED(Anode)
4	NC	No Connect
5	LED4	Power supply for LED(Cathode)
6	LED5	Power supply for LED(Cathode)
7	LED6	Power supply for LED(Cathode)
8	LED7	Power supply for LED(Cathode)
9	GND	Ground
10	GND	Ground
11	MRP_2P	MRP date positive signal (2P)
12	MRP_2N	MRP date positive signal (2N)
13	GND	Ground
14	MRP_1P	MRP date positive signal (1P)
15	MRP_1N	MRP date positive signal (1N)
16	GND	Ground
17	MRP_CLKP	MRP CLK positive signal (CLKP)
18	MRP_CLKN	MRP CLK positive signal (CLKN)
19	GND	Ground
20	MRP_DP	MRP date positive signal (DP)
21	MRP_DN	MRP date positive signal (DN)
22	GND	Ground
23	MRP_3P	MRP date positive signal (3P)
24	MRP_3N	MRP date positive signal (3N)
25	GND	Ground
26	NC	Ground
27	RESIST	Resist Pin
28	GND	Ground
29	VDDIO	Logic power 1.8V
30	VDD	Logic power 3.3V
31	VDD	Logic power 3.3V

SMC	DESCRIPTION OF REVISION	REASON	REVISED BY	DATE
△	first issue	A	XC-SU	2024/09/25

Amson

YU DU AMSON ELECTRONICS Co., Ltd.

于都上晴电子有限公司

YU DU AMSON ELECTRONICS Co., Ltd.

TITLE: OUTLINE DIMENSION

D/N: AM-8001280-070E

Rev: A

SCALE: 1 : 1

UNITS: mm

APPROVED BY: _____

CHECKED BY: _____

DRAWN BY: _____

喷码

99070E-128131-54800 YYY/WW/00

插接方向

3. PIN DESCRIPTION

PIN NO.	Symbol	Description	Remarks
1	LED+	Power supply for LED (Anode)	
2	LED+	Power supply for LED (Anode)	
3	LED+	Power supply for LED (Anode)	
4	NC	No Connect	
5	LED-	Power supply for LED (Cathode)	
6	LED-	Power supply for LED (Cathode)	
7	LED-	Power supply for LED (Cathode)	
8	LED-	Power supply for LED (Cathode)	
9	GND	Ground	
10	GND	Ground	
11	MIPI_2P	MIPI data positive signal (2P)	
12	MIPI_2N	MIPI data positive signal (2N)	
13	GND	Ground	
14	MIPI_1P	MIPI data positive signal (1P)	
15	MIPI_1N	MIPI data positive signal (1N)	
16	GND	Ground	
17	MIPI_CLKP	MIPI CLK positive signal (CLKP)	
18	MIPI_CLKN	MIPI CLK positive signal (CLKN)	
19	GND	Ground	
20	MIPI_0P	MIPI data positive signal (0P)	
21	MIPI_0N	MIPI data positive signal (0N)	
22	GND	Ground	
23	MIPI_3P	MIPI data positive signal (3P)	
24	MIPI_3N	MIPI data positive signal (3N)	
25	GND	Ground	
26	NC		
27	RESET	Reset Pin	
28	GND	Ground	
29	VDDIO	Logic power 1.8V	
30	VDD	Logic power 3.3V	
31	VDD	Logic power 3.3V	

4 Electrical Specifications

Table 3 Electrical Specifications

No.	Item	Min.	Typ.	Max.	Unit
1	Vcom voltage	(-1.34)	(-0.84)	(-0.34)	V
2	Frame Rate	(55)	(60)	(65)	Hz
3	VGH voltage	(14)	(15)	(16)	V
4	VGL voltage	(-12)	(-11)	(-10)	V

Note(1) Both VGH and VGL are TFT gate operation voltage.

Note(2) The setting of electrical parameters should follow the initial code specified by IVO. Vcom must be adjusted to optimize display quality.

Note(3) All the contents of electrical specifications and display fineness are guaranteed under Normal Conditions. Normal conditions are defined as follow: Temperature: 25°C, Humidity: 55± 10%RH.

5 Optical Characteristics

The optical characteristics are measured under stable conditions as following notes.

Table 4 Optical Characteristics

Item	Conditions	Min.	Typ.	Max.	Unit	Note	
Transmittance	Center	(4.5)	(5.0)	-	%	Under C-light (1),(5),(7),(8),(10) $\theta_x=\theta_y=0^\circ$	
Contrast Ratio	Center	(640)	(800)	-	-	(1),(3),(6),(7),(8) $\theta_x=\theta_y=0^\circ$	
Response Time	Rising + Falling	-	(25)	(TBD)	ms	(1),(4),(6),(7),(8) $\theta_x=\theta_y=0^\circ$	
CF Color Chromaticity (CIE1931)	Red x	Typ. -0.02	(0.632)	Typ. +0.02	-	Under C-light (1),(5),(8) $\theta_x=\theta_y=0^\circ$	
	Red y		(0.329)		-		
	Green x		(0.267)		-		
	Green y		(0.502)		-		
	Blue x		(0.139)		-		
	Blue y		(0.119)		-		
	White x		(0.299)		-		
	White y		(0.322)		-		
NTSC	CIE1931	(45)	(50)	-	%		
Viewing Angle (CR≥10)	Horizontal	θ_{x+}	(75)	(85)	-	degree	(1),(2),(6),(7),(8)
		θ_{x-}	(75)	(85)	-		
	Vertical	θ_{y+}	(75)	(85)	-		
		θ_{y-}	(75)	(85)	-		

Note(1) Measurement Setup:

The LCD module should be stabilized at given ambient temperature (25°C) for 30 minutes to avoid abrupt temperature changing during measuring. In order to stabilize the luminance, the measurement should be executed after lighting backlight for 30 minutes in the windless room.

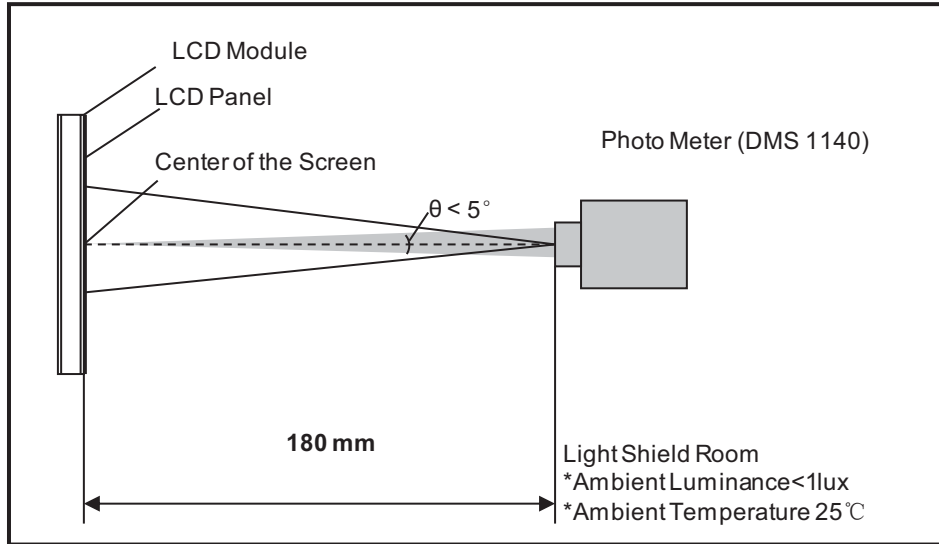

Figure 1 Optical Characteristic Measurement Equipment and Method

Note(2) Definition of Viewing Angle.

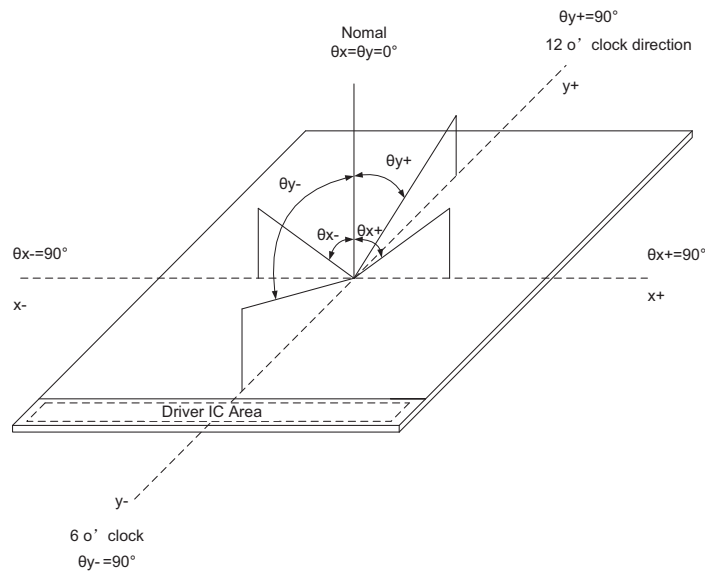

Figure 2 Definition of Viewing Angle

Note(3) Definition of Contrast Ratio (CR)

The contrast ratio can be calculated by the following expression:

Contrast Ratio (CR) = the luminance of White pattern/ the luminance of Black pattern

Note(4) Definition of Response Time

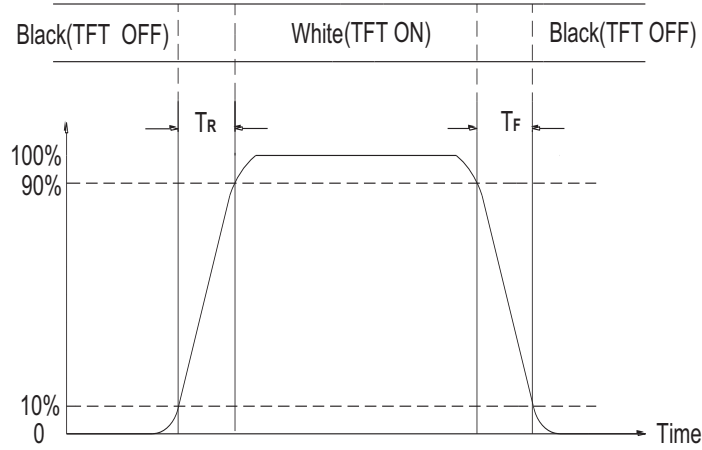

Figure 3 Definition of Response Time

Note(5) C-light Spectrum

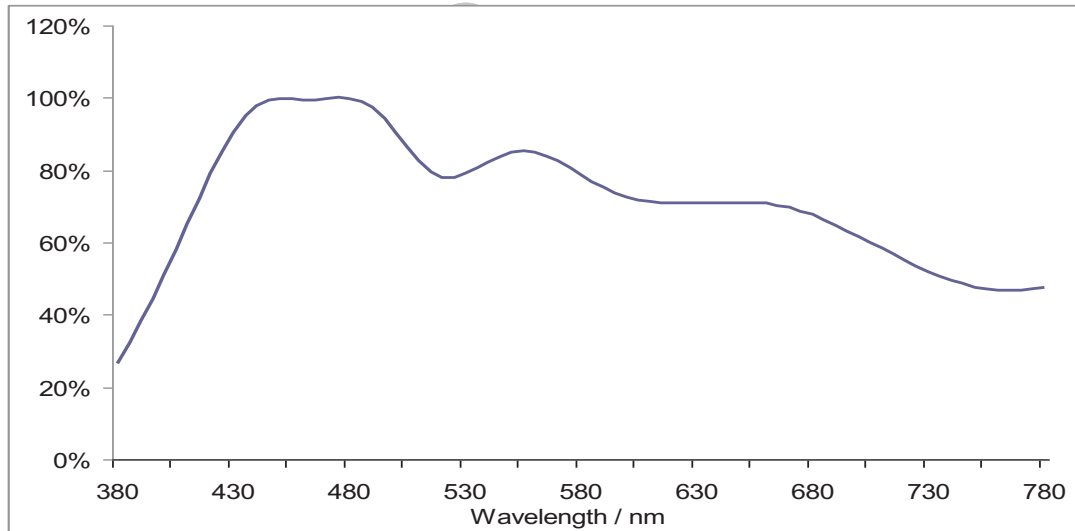

Figure 4 C-Light Spectrum

Note(6) The Back Light Spectrum

TBD

Figure 5 Back Light Spectrum

Note(7) The polarizer type: TBD

Note(8) All optical data are based on IVO given system & nominal parameter & testing machine in this document.

Note(9) The direction of polarizer. It is recommended that customer should choose O Mode or E Mode according to the actual situation.

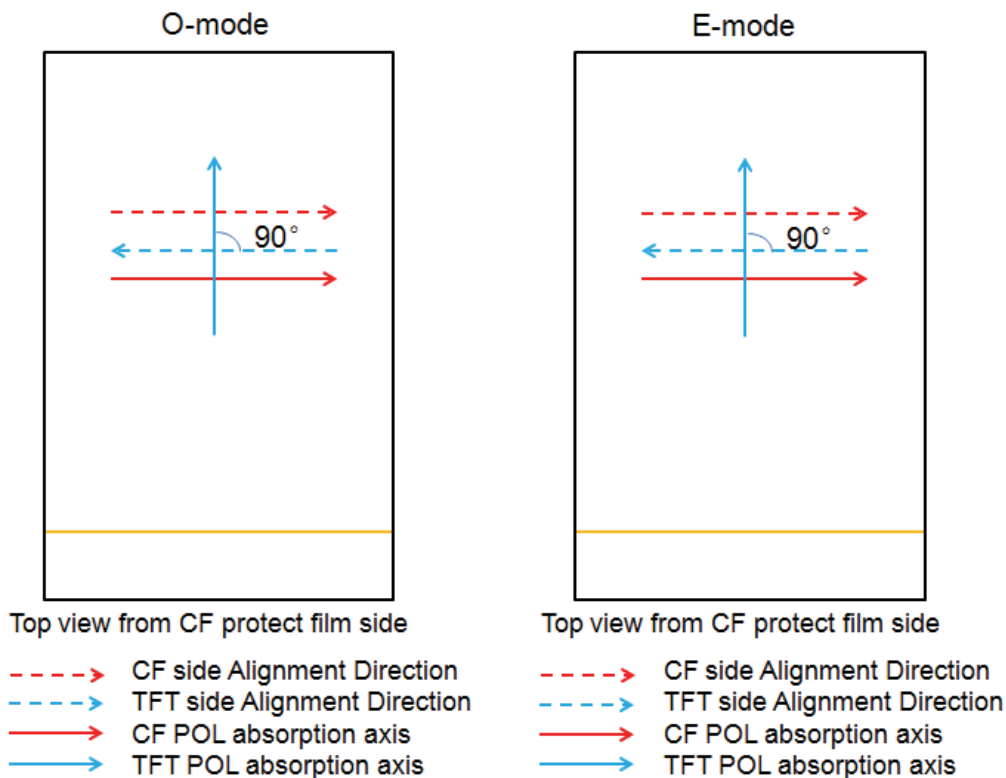

Figure 6 Polarizer Direction

Note(10) Considering each custom's spectrum of BL is different, we define transmittance spec based on C-light source (standard light source). The differences may exist, when measure transmittance with unlike BL spectrum. if you have any questions, please contact IVO FAE.

6. Pixel Format

The figure shows the relation of the input signals and LCD panel pixel format.

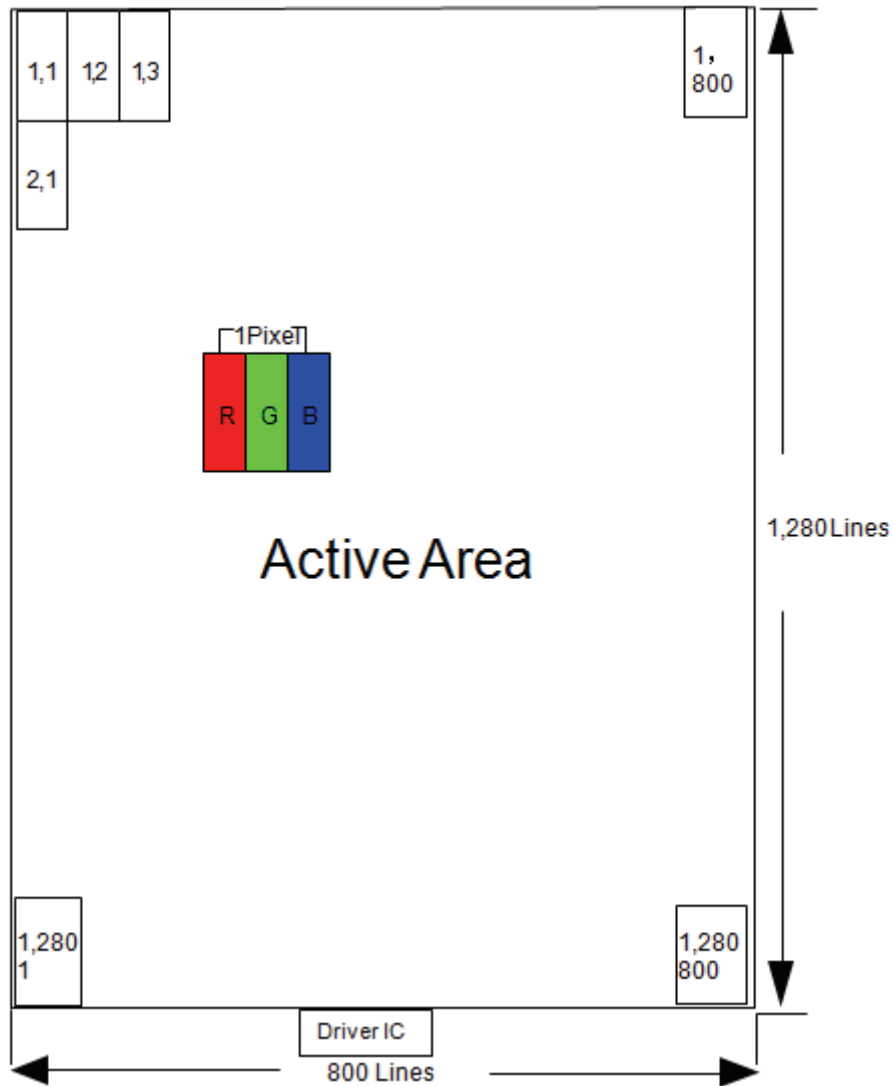

Figure 7 Pixel Format

7. RELIABILITY TEST ITEMS

7.1 TEMPERATURE AND HUMIDITY

Test Item	Test Condition	Remark
High Temperature Storage	Ta=60°C; 72hrs	IEC60068-2-1: 2007 GB2423.2-2008
Low Temperature Storage	Ta=-20°C; 72hrs	IEC60068-2-1: 2007 GB2423.1-2008
High Temperature Operation	Ta=50°C; 72hrs	IEC60068-2-1: 2007 GB2423.2-2008
Low Temperature Operation	Ta=-10°C; 72hrs	IEC60068-2-1: 2007 GB2423.1-2008
High Temperature High Humidity Operation	Ta=50°C, 90%RH, 72Hrs(no condensation)	IEC60068-2-78: 2001 GB/T2423.3-2006
Thermal Shock	-20°C (0.5h) ~ 60°C (0.5h) / 10cycles	Start with cold temperature , End with high temperature, IEC60068-2-14:1984,GB2423.22-2002
Image Sticking	25°C ; 2hrs	Note1

Note1:Condition of image sticking test :25°C ±2°C

Operation with test pattern sustained for 2hrs,then change to gray pattern immediately.after5 mins,themura must be disappeared completely

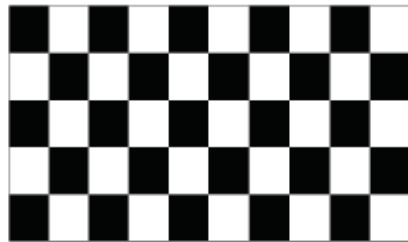

(a) Test Pattern (chess board Pattern)



(b) Gray Pattern

7.2ESD

Test item	Conditions	Remark	
Electro Static Discharge Test (non-operation)	150pF, 330Ω, Contact:±3KV,Air:±8KV	1	IEC61000-4-2: 2001 GB/T17626.2-2006
	200pF, 0Ω, ±200V contact test	2	

Note: Measure point :

1. LCD glass and metal bezel
2. IF connector pins

8. GENERAL PRECAUTION

8.1 SAFETY

1. Do not swallow any liquid crystal, even if there is no proof that liquid crystal is poisonous.
2. If the LCD panel breaks, be careful not to get liquid crystal to touch your skin.
3. If skin is exposed to liquid crystal, wash the area thoroughly with alcohol or soap.

8.2 STORAGE CONDITIONS

1. Store the panel or module in a dark place where the temperature is $23\pm 5^{\circ}\text{C}$ and The humidity is below $50\pm 20\%RH$.
2. Store in anti-static electricity container.
3. Store in clean environment, free from dust, active gas, and solvent.
4. Do not place the module near organics solvents or corrosive gases.
5. Do not crush, shake, or jolt the module.

8.3 HANDLING PRECAUTIONS

1. Avoid static electricity which can damage the CMOS LSI.
2. The polarizing plate of the display is very fragile. So, please handle it very carefully.
3. Do not give external shock.
4. Do not apply excessive force on the surface.
5. Do not wipe the polarizing plate with a dry cloth, as it may easily scratch the Surface of plate.
6. Do not use ketonics solvent & Aromatic solvent, use with a soft cloth soaked with a cleaning naphtha solvent.
7. Do not operate it above the absolute maximum rating.
8. Do not remove the panel or frame from the module.
9. When the module is assembled, it should be attached to the system firmly, Be careful not to twist and bend the module.
10. Wipe off water droplets or oil immediately. If you leave the droplets for a long time, staining and discoloration may occur.
11. If the liquid crystal material leaks from the panel, it should be kept away from the eyes or mouth in case of contact with hands, legs or clothes, it must be washed away thoroughly with soap.

8.4 WARRANTY

1. The period is within twelve months since the date of shipping out under normal using and storage conditions.
2. Do not repaired or modified the LCM. It may cause function to lose efficacy, Starry does not warrant the LCM.
3. All process and material comply ROHS.

9. PACKAGE DRAWING

